

CYCLE RACK DETAIL  
TYPE 1

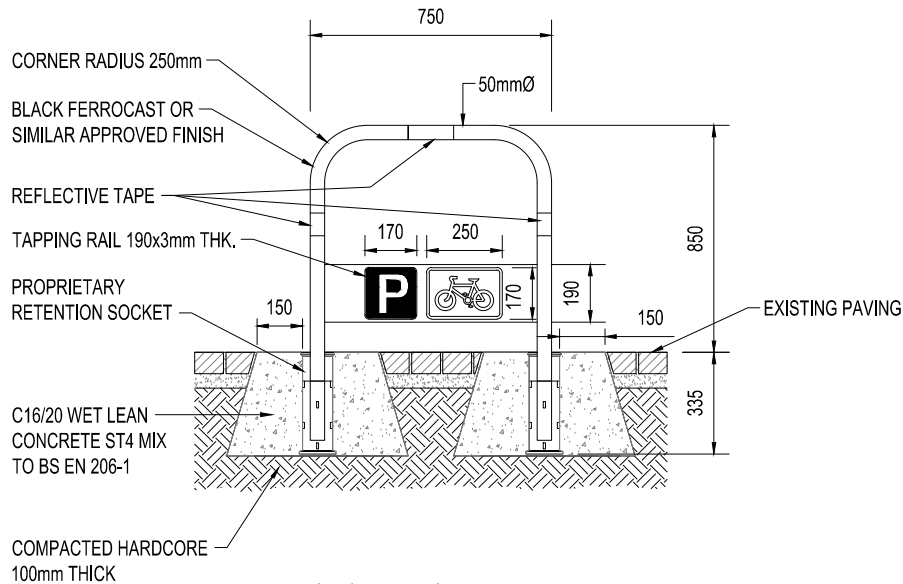

CYCLE RACK DETAIL  
TYPE 2

**NOTES:**

1. ALL DRAWING DIMENSIONS IN MILLIMETRES
2. TYPE 2 CYCLE RACKS TO BE USED AT BOTH ENDS OF CYCLE RACK INSTALLATIONS OR IN ISOLATION. TYPE 1 TO BE USED AT INTERMEDIATE POSITIONS.
3. CYCLE RACKS TO BE SUPPLIED WITH BLACK GLOSS, HIGH CHIPPING RESISTANT, HIGH ABRASION RESISTANT FINISH (FERROCAST OR SIMILAR APPROVED).
4. CURRENT STANDARD: LONDON CYCLING DESIGN STANDARDS
5. PARKING AND CYCLE SYMBOLS TO APPEAR ON BOTH SIDES OF TAPPING RAIL.

© Crown copyright. All rights reserved City of Westminster LA 100019597

PROJECT:	STANDARD DETAILS
TITLE:	CYCLE RACK AND SIGN DETAIL (PROPRIRITARY SOCKET FOUNDATION)

A	15.04.16	PAD	INITIAL ISSUE	DD	RV
REV	DATE	BY	DESCRIPTION	CHK	APD
SCALE: 1:25				A4	
DRAWING No: SD-03-01				REV: A	

